



Bell and Gong System ZBG110

The ZÖLLNER Bell and Gong System ZBG110 is an electronic device to fulfill the requirements of the COLREG 1972, Rule 33(a)

„...a vessel of 20 metres or more in length shall be provided with a bell..., and a vessel of 100 metres in length shall, in addition, be provided with a gong. ...manual sounding ... shall always be possible.“

The system consists of:

- » one electronic bell ZB110 (including one loudspeaker and one control unit)
- » one electronic gong ZG110 (including one loudspeaker and one control unit)
- » one signal automaton 10+SGA (to be ordered separately).

To fully comply with the rule, a manual bell and gong must supplement the electronic system.

Essentials

- » full compliance with the COLREG 1972
- » type approved by international maritime authorities
- » individual certificates by classification societies on request
- » available for 230 V AC, 115 V AC or 24 V DC

Sound characteristics

- » unequivocal sound of bell and gong ZBG110
- » identical to conventional types
- » sound pressure level of 110 dB at 1 m distance

Advantages

- » maintenance free
- » latest technical standard
- » best material and workmanship - made in Germany



Technical information

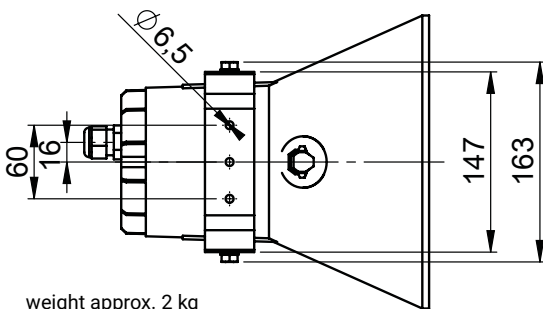
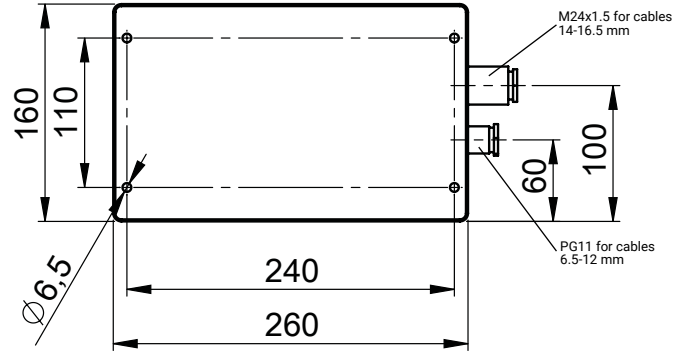
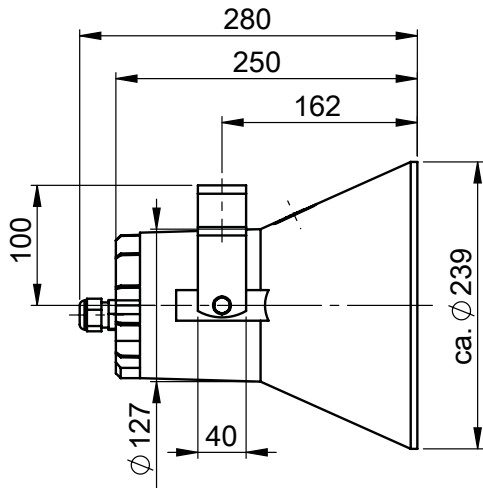

weight approx. 2 kg

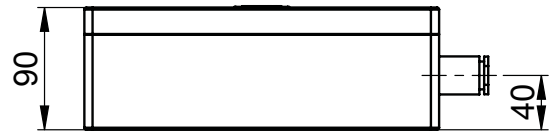

weight approx. 3 kg

Connecting Example

